

Semi-Automatic Bagger



Semi-Automatic High Speed Single Tier Bagger



Faster, Cleaner, Economical

Custom designed for your production line and container size, our High speed semi-automatic Single Tier Bagger eliminates the need for costly slip-sheeting, allowing the machine to run at faster speeds than current bagging systems. Your product will store cleaner and you will save money by eliminating operator time and material costs.

Also available in our multi-pack version. You can now run your smaller bottles on our semi automatic bagger. Pack sizes can be changed easily using our interactive PLC touch screen.



Floor Plan Template:

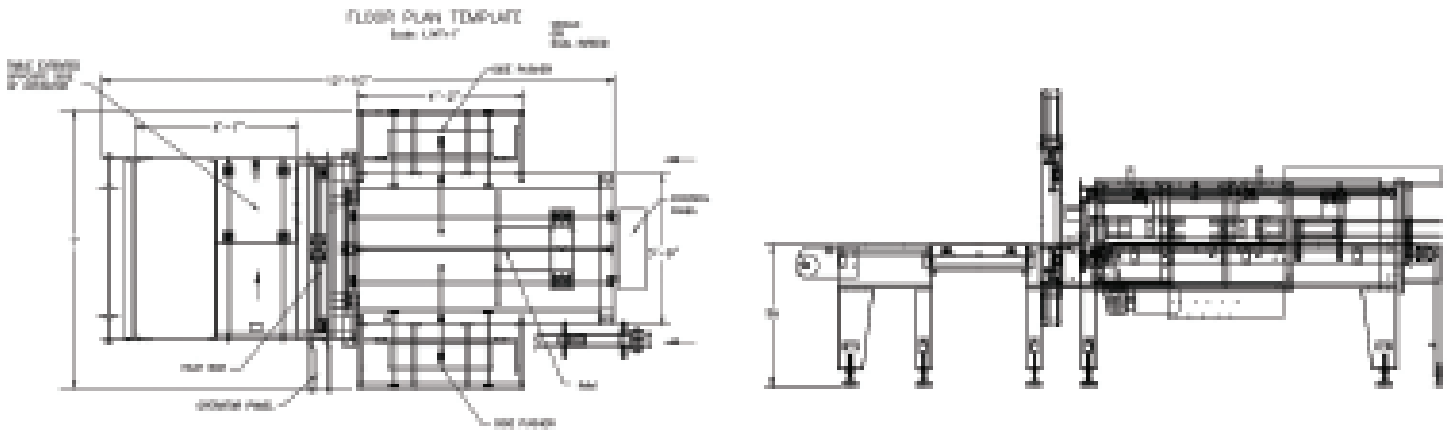

Semi-Automatic Bagger

- Dual infeed machine shown.
- Customer to specify operator side of machine.
- 1 Gal. 6 x 8 bag.
- 1/2 Gal. 9 x 12 bag.

Above bag sizes are equal. Non gallon and 1/2 gallon bags can vary in size.

Power and air requirements:

- 120V, 1 P, 60~
- Air: 100 PSI.